

Request for quote: Quotation Budgetary Estimate

SOCITEC US LLC 2443 Braga Drive Broadview, Illinois 60155-3941 Telephone: 800-842-7668 or 708-345-2050 Fax: 708-345-2225 www.vibro-dynamics.com Email: vibro@vibroynamics.com		<input type="checkbox"/> New Customer	Quote No. _____
		Customer Number: _____	Date: _____
(For office use only)		Salesman: _____	
		Territory: _____	

Name: _____	Phone: _____	Send quote via: <input type="checkbox"/> Fax <input type="checkbox"/> Email <input type="checkbox"/> Mail
Title: _____	Fax: _____	
Company: _____	Email: _____	
Address _____	City: _____	
State/Province: _____ Postal _____	Country: _____	

For the following data please indicate units of measure: English Metric

1. MACHINE TOOL DATA

Manufacturer:
 Model number: Serial number:
 Type: (e.g. I.D. grinder, vertical machining center, jig borer, etc.)
 Control type: CNC Manual Other:
 Machine weight: Maximum part weight:
 Maximum tooling weight: Weight of fixtures (if any):
 Number of mounting points: (See section 6 on next page for more on mounting points)

2. OPERATING SPEED RANGES

Main tool spindle or chuck: RPM Horizontal or Vertical
 Motor spindle: RPM Horizontal or Vertical
 Other rotating member: RPM Horizontal or Vertical
 Describe other rotating member:
 Is there a balancer? Yes No What type?

3. TABLE TRAVERSE (if applicable)

Moving weight: Which Axis? X Y Z
 Maximum acceleration: Fill in those that apply
 Maximum velocity:

4. OTHER TRAVERSE ACTIONS (if applicable)

Moving weight: Describe action: _____
 Maximum acceleration: Which Axis? X Y Z
 Maximum velocity: Fill in those that apply

5. PLEASE PROVIDE A GENERAL ASSEMBLY DRAWING, IF POSSIBLE

6. CHECK TYPE OF MOUNTING POINT AND LIST APPLICABLE DIMENSIONS

For the following data, please indicate units of measure: English Metric

If blind tapped hole: Mounting hole diameter Pitch Depth

TYPE A

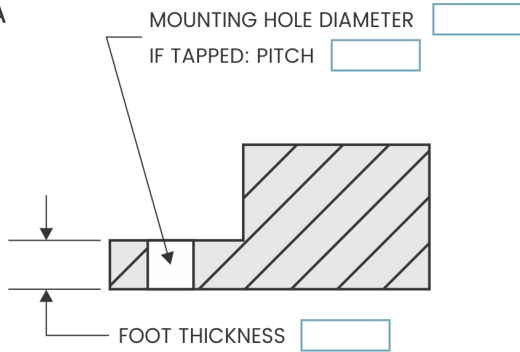

TYPE B

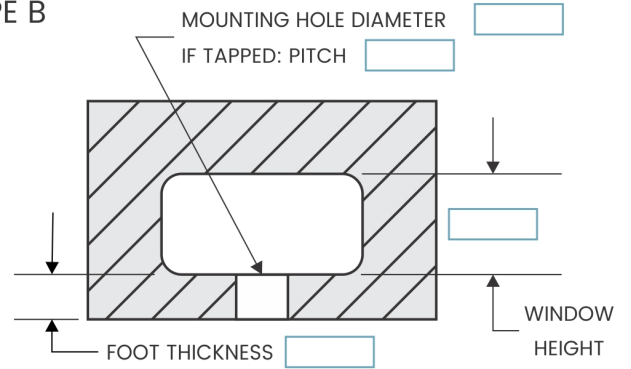

TYPE C

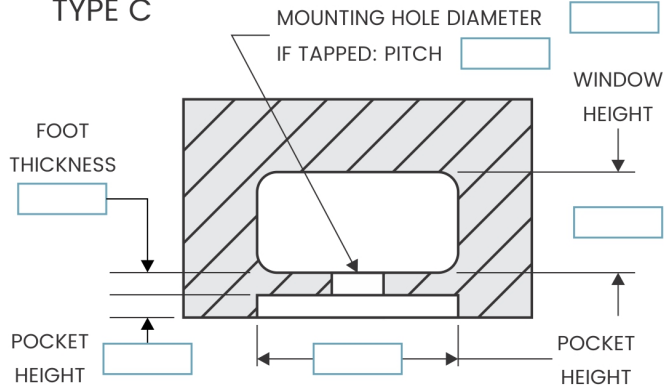

TYPE D

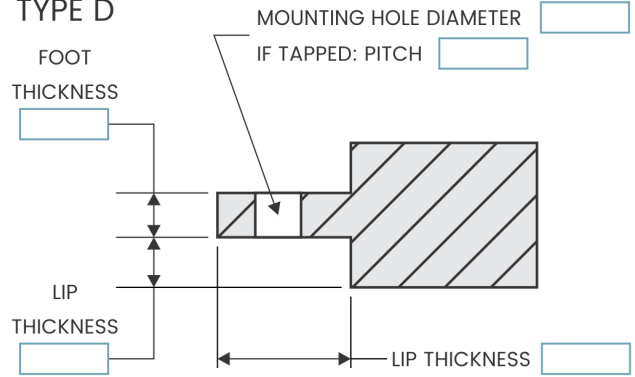

7. Use the space below for sketches and/or comments on any special considerations.