

- Excellent isolation for effective control of vibration and shock
- High-performance, multi-layer, modular elastomer construction
- Hydra/Level® Assisted Leveling
 - faster, easier leveling, alignment and elevation adjustment
 - preventative maintenance insurance in the event of foundation settling.
- Integrated precision leveling
 - more precise
 - infinitely adjustable
- Two degree swiveling capability for:
 - uniform support
 - elimination of foundation, grout, or sole plates

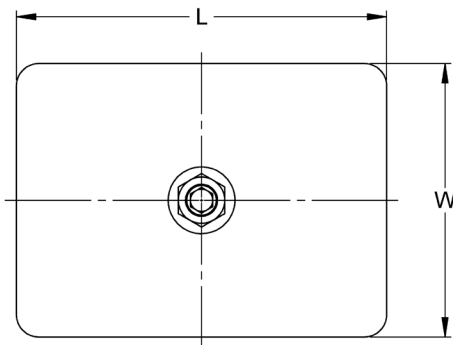

Hydraulic Cylinders used in MX Products are available from third party sources. See Specifications below.

Isolator Model	Cylinder Capacity		Number of Cylinders Required	Cylinder Dimensions				Cylinder Stroke	
				Diameter (max.)		Height (max.)			
	US Tons	MN		inch	mm	inch	mm	inch	mm
24MXL	30	0.27	2	4	102	4.63	118	2.44	62
25MXL	50	0.44	2	4.88	124	5	127	2.38	60

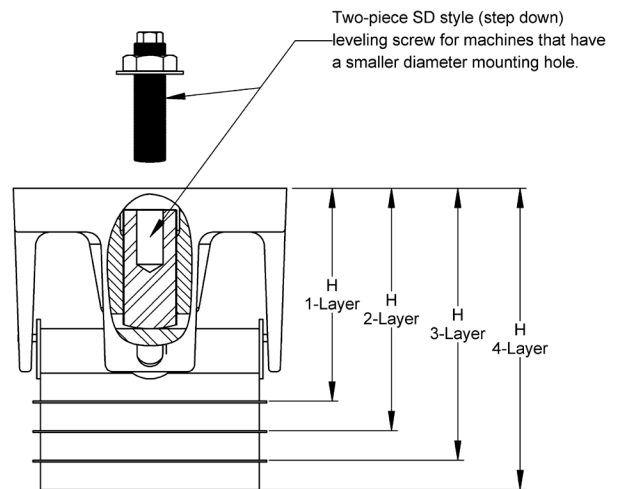
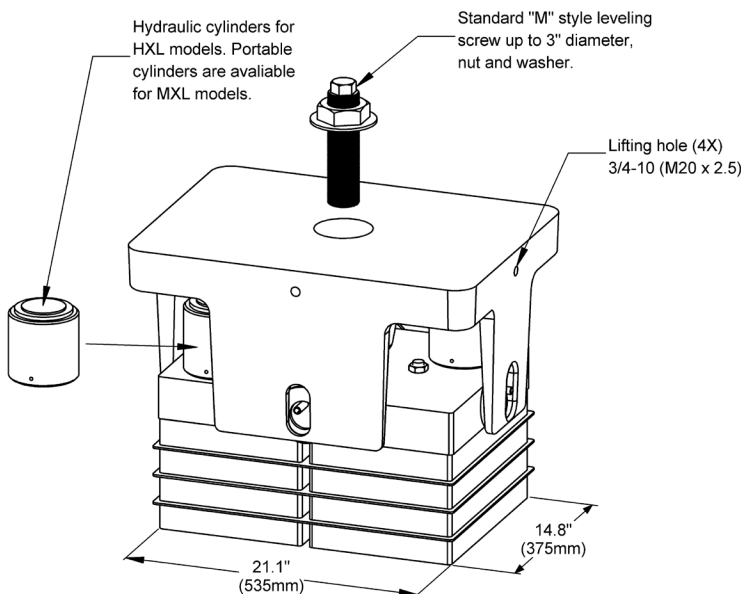

Isolator		L		W		H								Weight		
Series	Model	inch	mm	inch	mm	Min.		Max.		Tol. ±		Installed		lbs.	kg	
						inch	mm	inch	mm	inch	mm	inch	mm			
24MXL	1 Layer	24MXL0801	24.9	632	18.4	468	13.4	340	14.9	378	0.17	4.3	14.2	361	792	359
		24MXL0951	24.9	632	18.4	468	13.4	340	14.9	378	0.17	4.3	14.2	361	793	360
		24MXL1241	24.9	632	18.4	468	13.0	330	14.5	368	0.17	4.3	13.8	351	788	358
25MXL	1 Layer	25MXL1441	24.9	632	18.4	468	13.3	338	14.8	376	0.17	4.3	14.1	358	829	376
		25MXL1601	24.9	632	18.4	468	12.9	328	14.4	366	0.17	4.3	13.7	348	824	374
24MXL	2 Layer	24MXL0802	24.9	632	18.4	468	15.3	389	16.8	427	0.19	4.8	16.1	409	844	383
		24MXL0952	24.9	632	18.4	468	15.3	389	16.8	427	0.19	4.8	16.1	409	845	383
		24MXL1242	24.9	632	18.4	468	14.6	371	16.1	409	0.19	4.8	15.4	391	835	379
25MXL	2 Layer	25MXL1442	24.9	632	18.4	468	14.6	371	16.1	409	0.19	4.8	15.4	391	873	396
		25MXL1602	24.9	632	18.4	468	13.9	353	15.4	391	0.19	4.8	14.7	374	862	391
24MXL	3 Layer	24MXL0803	24.9	632	18.4	468	17.1	434	18.6	472	0.21	5.3	17.9	455	895	406
		24MXL0953	24.9	632	18.4	468	17.1	434	18.6	472	0.21	5.3	17.9	455	897	407
		24MXL1243	24.9	632	18.4	468	16.1	409	17.6	447	0.21	5.3	16.9	429	882	400
25MXL	3 Layer	25MXL1443	24.9	632	18.4	468	15.9	404	17.4	442	0.21	5.3	16.7	424	918	417
		25MXL1603	24.9	632	18.4	468	14.9	378	16.4	417	0.21	5.3	15.7	399	901	409
24MXL	4 Layer	24MXL0804	24.9	632	18.4	468	19.0	483	20.5	521	0.22	5.6	19.8	503	936	425
		24MXL0954	24.9	632	18.4	468	19.0	483	20.5	521	0.22	5.6	19.8	503	938	426
		24MXL1244	24.9	632	18.4	468	17.7	450	19.2	488	0.22	5.6	18.5	470	919	417
25MXL	4 Layer	25MXL1444	24.9	632	18.4	468	17.3	439	18.8	478	0.22	5.6	18.1	460	951	431
		25MXL1604	24.9	632	18.4	468	15.9	404	17.4	442	0.22	5.6	16.7	424	928	421

Leveling Screw Model	Foot Thickness To:	
	inch	mm
2.5M14	2.1	53
2.5M16	4.1	104
2.75M14	1.9	48
2.75M16	3.9	99
3M14	1.8	46
3M16	3.8	97
1.5SD8	1.5	38
1.5SD10	3.5	89
1.5SD12	5.5	140
1.5SD14	7.5	191
1.5SD16	9.5	241
1.75SD8	1.0	25
1.75SD10	3.0	76
1.75SD12	5.0	127
1.75SD14	7.0	178
1.75SD16	9.0	229
2SD10	2.5	64
2SD12	4.5	114
2SD14	6.5	165
2SD16	8.5	216

Custom Sizes are Available

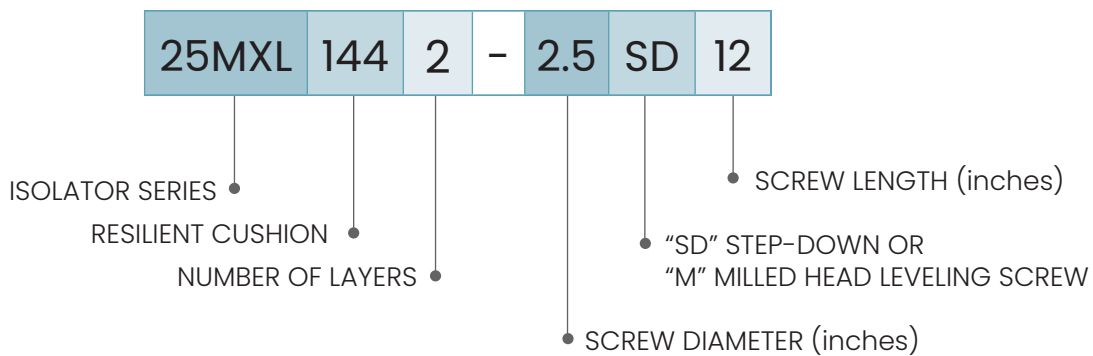

- TYPICAL APPLICATIONS**
- Presses, Mechanical
 - Forging Presses
 - Transfer Presses
 - Hydraulic Presses
 - Isolated Foundations
 - Structures

NOTE: Isolator data subject to change without notice.

09/19/2023

