

**Technical Bulletin M/L – 698**  
**Installation and Leveling Instructions for**  
**Vibro/Dynamics® FSV & FSX Spring Isolators.**

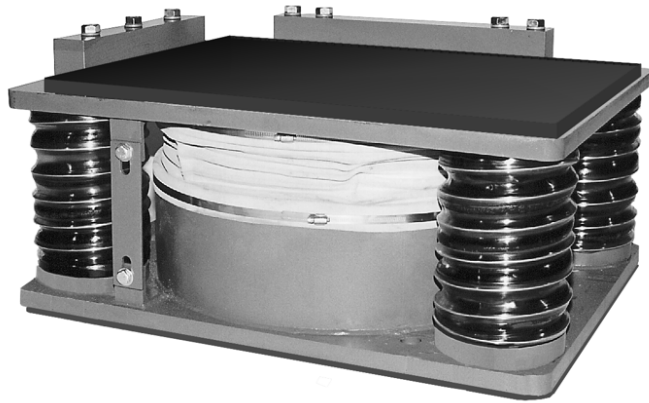

**FS Style Mount**

Vibro/Dynamics Technologically Advanced Machinery Mounting Systems are an investment in productivity and efficiency. To realize the full potential of your investment, familiarize yourself with these instructions and use them as a reference during the installation.

© Copyright 2020 Vibro/Dynamics® LLC  
All Rights Reserved

## INSTALLATION AND LEVELING INSTRUCTIONS

### Installation Requirements

1. There should not be any solid connections between the machine and the foundation or building structure. Flexible connections are recommended for plumbing and electrical conduit. Floor plates, walkways, railings, etc. should not be attached to both the machine and the floor, foundation or building. Hard connections will “short-circuit” isolation effectiveness.
2. The concrete surface under the isolator must be clean, flat (see table below), and have a brushed finished. There should not be any holes, cracks, or lumps under the isolator.

### ISOLATOR SLOPE TOLERANCE TABLE

The slope of the supporting surface under the isolator must not exceed the tolerances below. Uneven loading of the coil springs occurs when the isolator is tilted, causing excessive stress. Sole or Grout Plates are required for supporting surfaces exceeding the tolerances shown below.

ISOLATOR MODEL	SLOPE TOLERANCE	
	inches/foot	mm/meter
FSV14	0.12	10
FSV1908-3	0.12	10
FSV20 and FSX20	0.07	5.8
FSV24	0.07	5.8

3. Clean and inspect the machine base/anvil. Repair any cracks or damage. The bottom of the machine base/anvil must be clean and flat where it contacts the top of the isolator.
4. For forging press applications, clean any debris from the mounting holes.

### Isolator Installation

5. Position each isolator under the machine foot base or anvil. For isolators equipped with hold-down bolts, position the isolator under the machine foot so that the tapped hole in the isolator is concentric with the machine’s mounting hole as per Figure 1.
6. For Hammer and Die Forger installations, position the isolators under the anvil as per Figure 2.
7. Remove the two shipping straps that hold the upper and lower of isolator together.
8. Lower the machine onto the isolator. For isolators equipped with hold-down bolts, insert the hold-down bolt through the hole in the machine foot and thread into the tapped hole in the top of the isolator.
9. For Hammer and Die Forger installations using more than four FSV or FSX isolators, the height of each isolator should be measured to determine if it is carrying proper load. All isolator heights should be within 0.1” (2.5 mm) of each other. If not, insert shims between the higher isolator(s) and the machine base until all isolators are within the height specification. Shims should be made from either thin rubber sheet or steel with an anti-slip coating.

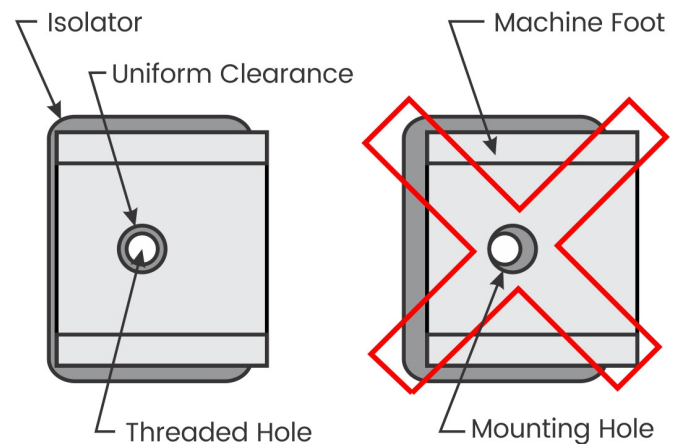
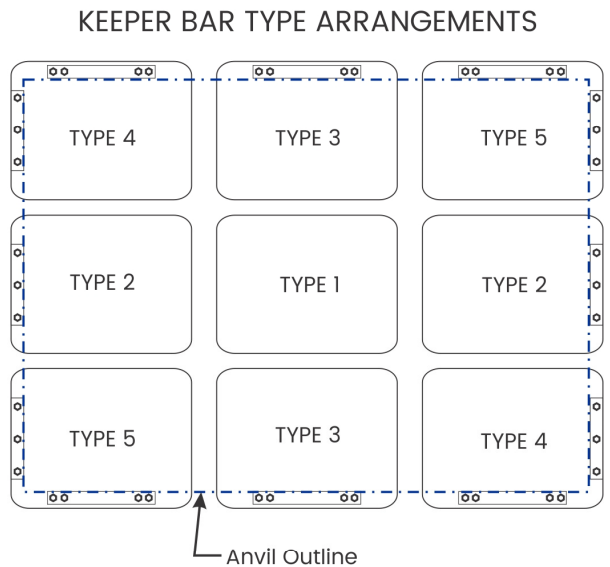
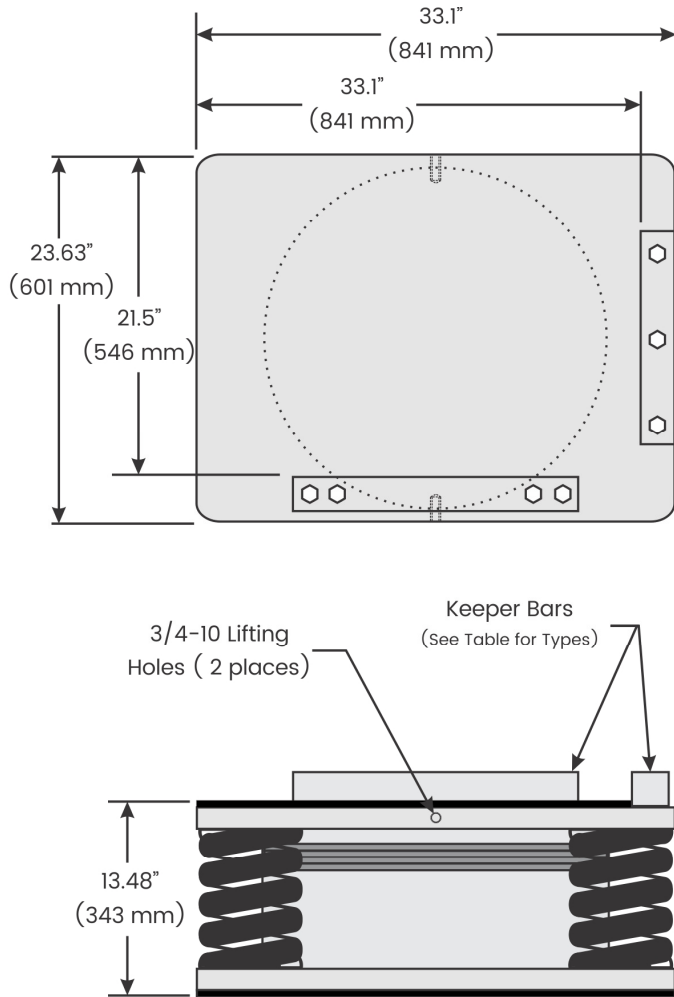

Figure 1

# TECHNICAL BULLETIN: M/L-698



## Notes:

1. Isolator Type is indicated by a suffix added to the Model Number. For example, FSV20-164-T1 indicates a Type 1 Keeper Bar Arrangement.
2. The Surface that the Isolator sets upon must not be Sloped more than 5.8 mm/m.

Figure 2

## Leveling

10. Refer to the machine manual for the machine's leveling locations and tolerances.
11. Using a precision machinists' level, or laser, determine the machine's low side in the front-to-back direction.
12. Raise all of the isolators on the low side an equal amount until the machine is level in that direction. Repeat procedure in the left-to-right direction.
13. Repeat Steps 10 & 11 until the machine is level.

**Caution:** Vibro/Dynamics Isolators do not bolt to the floor and should not be used to mount machines that depend on anchor bolts to keep them from tipping or collapsing.