

## Installation and Leveling Instructions for Micro/Level® Isolators

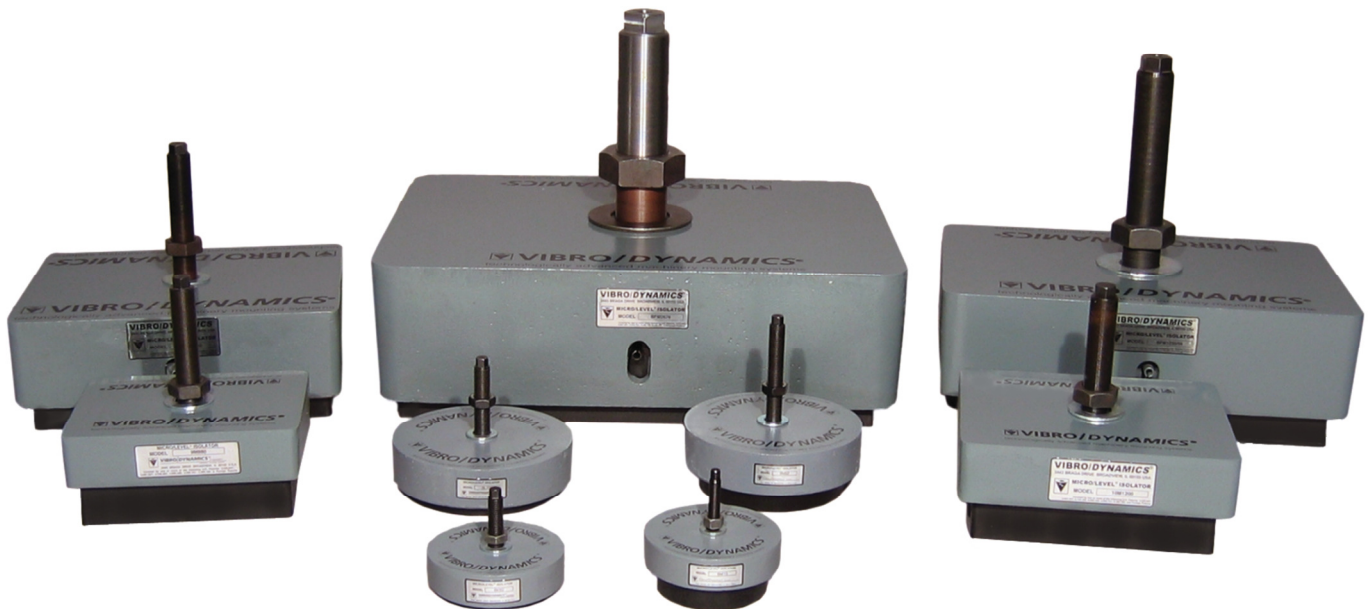

Vibro/Dynamics' Technologically Advanced Machinery Mounting Systems are an investment in productivity and efficiency. To realize the full potential of your investment, familiarize yourself with these instructions and use them as a reference during the installation.

The way that your machine is installed has a significant effect on its performance. The four conditions required for a good machine installation and best performance are:

- machine bed in one plane (level)
- precise alignment and parallelism of machine structure
- proper support
- effective control of vibration.

Vibro/Dynamics' Isolators make it possible to accomplish all of these steps to an ultra-high degree of precision and to do so very quickly. When the machine is fine-tuned and leveled, the machine will produce high quality parts with minimum wear and tear on dies and machine components. Downtime, noise, and vibration will be reduced, and productivity and efficiency will be increased.

**Note:** Vibro/Dynamics Isolators are referred to throughout this document and grouped by series according to their model number. Either the first number(s) or the first three letters of the isolator's model number determine the isolator series (e.g. – 8L70 .75M6 = 8 Series, BFM2690 2.5M10 = BFM Series, 16M3000 1.5M8 = 16 Series).

© Copyright 2019 Vibro/Dynamics LLC

## INSTALLATION AND LEVELING INSTRUCTIONS

### PREPARATION

1. The concrete surface under the isolator must be clean, flat, and trowel finished. There should not be any holes, cracks, or lumps directly under the isolator. Patch all holes and broken concrete.
2. Clean and inspect the machine feet and legs. Repair any cracks or damage. The bottom of the machine feet must be clean and flat where it contacts the top of the isolators. Clean any debris from the mounting holes.

### INSTALLATION

3. Position each isolator under the machine foot so there is uniform clearance between the threaded hole in the isolator and the inside surface of the mounting hole. (see Figure 1) Any contact between the leveling screw and the inside surface of the mounting hole as it is turned into the isolator housing can cause the leveling screw to jam. Note: The larger model BFM series are shipped with the preinstalled leveling screws. The isolator should be installed as a unit to the bottom of the machine foot. A two-piece sleeve is provided to protect the leveling screw as it is inserted through the mounting hole. Once installed, remove the top, longer sleeve and install the locknuts tightly against the machine foot. Carefully lower the machine. The short sleeve should remain installed to protect the leveling screw from contact with the mounting hole. If your isolators have preinstalled leveling screws, proceed to Step 7.

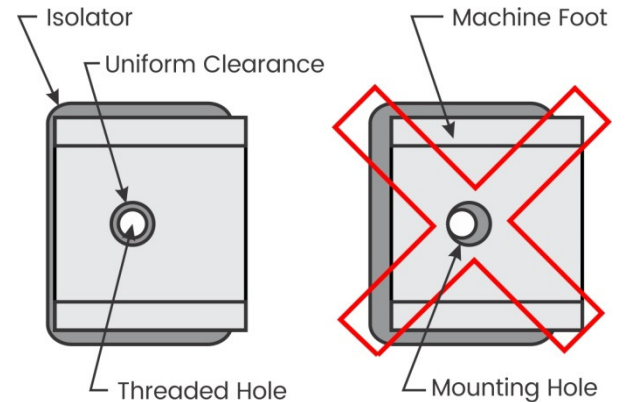

Figure 1

4. Carefully lower the machine onto the isolator. Be sure that no metal chips or debris falls into the isolator's threaded hole. This may cause the leveling screw to jam. Remove the orange protective plug from the tapped hole if supplied with the isolator.
5. Thread the leveling screw into the isolator by hand or with a small wrench. The leveling screw should turn easily into the isolator housing until it contacts the internal bearing plate (see Figure 2). If it does not, remove the leveling adjustment screw and check for proper clearance, damaged thread, or debris in the threaded hole.
6. When the leveling screw contacts the bearing plate, turn the leveling screw one additional turn when using model 2 through 16 series isolators and two additional turns when using BFM series isolators. A hydraulic jack may be necessary to remove weight in order to turn the leveling screw. Do not use pipe extensions or a hammer to force the leveling screw to turn.

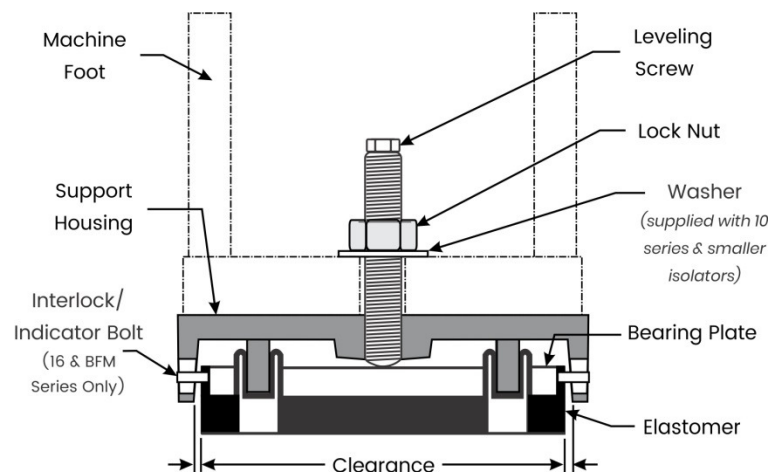

Figure 2 (Cutaway View)

## TECHNICAL BULLETIN: M/L-674

- For proper isolator performance, there should be clearance between the resilient cushion (elastomer) and the inside surface of the isolator's support housing as shown in Figure 2. If there is not clearance, lift the machine at that location and center the resilient cushion in the isolator housing.
- Models 16 and BFM series isolators are equipped with four Interlock/Indicator bolts or pins. These serve as a quick check for centering the resilient cushion. The Interlock/Indicators should be centered side-to-side in the interlock slots as shown in Figure 3A. If the resilient cushion is not centered, the Interlock/Indicators appear as shown in Figure 3B.

Correct!

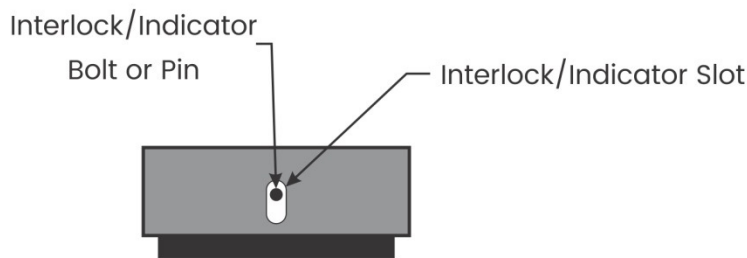

Figure 3A

Wrong!

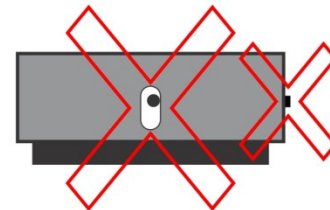

Figure 3B

### LEVELING

- Loosen the isolator's locknuts if tight.
- Refer to the machine manual for the machine's leveling locations and tolerances.
- Using a precision machinists' level, electronic level, or laser, determine the machine's low side in the left-to-right direction. Raise all of the isolators on the low side an *equal* amount until the machine is level in that direction. Using a hydraulic jack will make the process easier on heavy machines.
- Repeat procedure in the front-to-back direction.
- Repeat Steps 11 and 12 until the machine is level.
- Isolators should not be over-adjusted to compensate for extreme out-of-level floor or foundation conditions. If a severe out-of-level condition exists, a spacer plate can be inserted between the isolator and the machine foot. Refer to Isolator Specification Sheets or drawings 11387, 11388, 11646, or 11647 for isolator dimensions and leveling adjustment ranges.

Note: The Interlock/Indicators on the 16 and BFM Series isolators can be used to quickly determine the amount of leveling adjustment available. Figure 4 shows an isolator that has reached its maximum leveling adjustment.

Isolator Adjusted Too High!

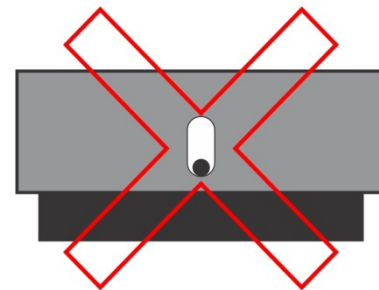

Figure 4

## TIGHTEN LOCKNUTS

- Locknuts are provided to fasten the Vibro/Dynamics Isolators to the machine feet. Use a wrench to hold the head of the leveling screw while tightening the locknut. Washers are supplied with isolator series up to and including 27 Series, with leveling screw diameters up to and including 3.0”.

## ADDITIONAL CONSIDERATIONS

- A rust proofing formulation should be applied to the isolator leveling screws if a machine is frequently washed-down with a water-based solution. Rust can cause the leveling screw to jam over time.
- There should not be any solid connections between the machine and the foundation or building structure. Flexible connections are recommended for all plumbing and electrical conduit. Floor plates, walkways, railings, feeds, rolling bolster rails, etc. should *not* be attached to *both* the machine and the floor, foundation or building (See Figure 5). Hard connections will “short-circuit” isolation effectiveness.

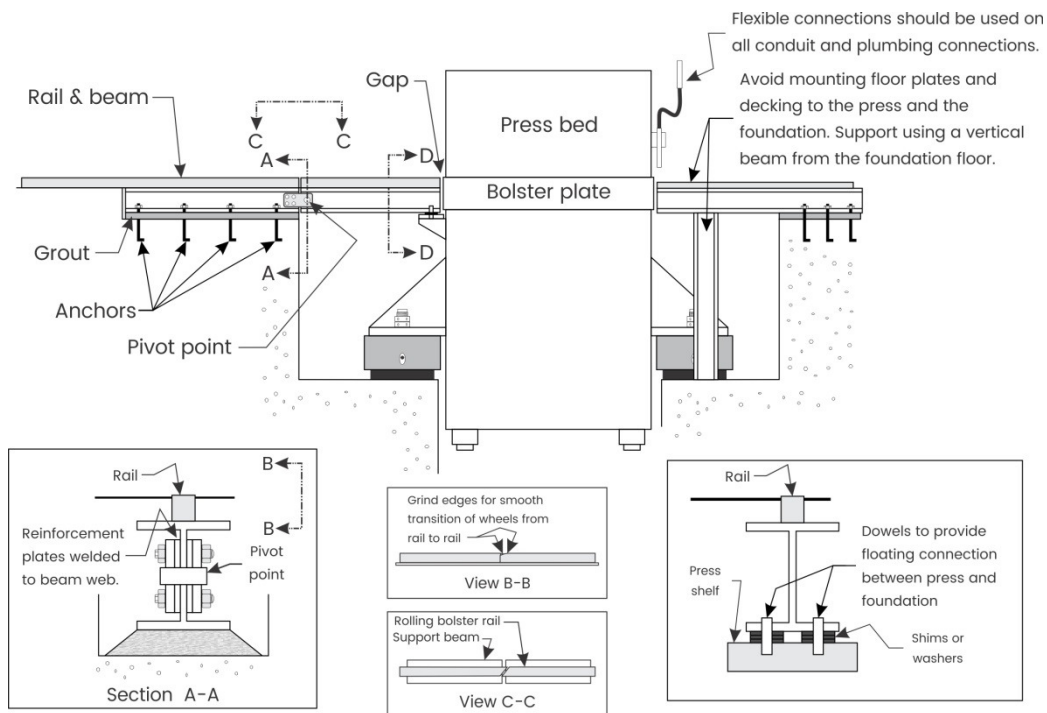

**FIGURE 5**

**Caution:** Vibro/Dynamics Isolators do not bolt to the floor and should not be used to mount machines that depend on anchor bolts to keep them from tipping or collapsing.

Call or write for assistance:

Vibro/Dynamics LLC  
2443 Braga Drive, Broadview, IL 60155-3941  
E-mail: [vibro@vibrodynamics.com](mailto:vibro@vibrodynamics.com)

1-800-842-7668 (USA only)  
1-708-345-2050 Tel.  
1-708-345-2225 Fax

Vibro/Dynamics®, Micro/Level®, Hydra/Level®, and Hy/Speed® are registered trademarks. All rights reserved

### Warranty

Vibro/Dynamics warrants equipment of its own manufacture to be free from defects in materials and workmanship. This warranty extends only to the original buyer; it is for one year only from the date of sale and is limited to repair or replacement, F.O.B. Vibro/Dynamics' plant, of any original part or component that Vibro/Dynamics finds to have been defective at the time of shipment. Vibro/Dynamics is not liable for consequential damages. This warranty is in lieu of all other warranties, expressed or implied.