

# MXL and MXLP Isolation Mounts for Large Stamping Presses

*Your Best Way to Install and Level Heavy  
Presses for Effective Vibration and Noise Control*

*Vibro/Dynamics specializes in the installation of large stamping presses on anchorless isolation systems that provide faster, easier installations.*

*MXL & MXLP Micro/Level® Isolators are elastomeric type mountings that provide excellent vibration isolation. Natural frequencies as low as 8 Hz are possible due to their unique multi-layer, modular elastomer design. MXL and MXLP models both feature integral precision leveling and hydraulic cylinder pockets, making leveling and alignment of even the heaviest presses accurate, fast and safe.*

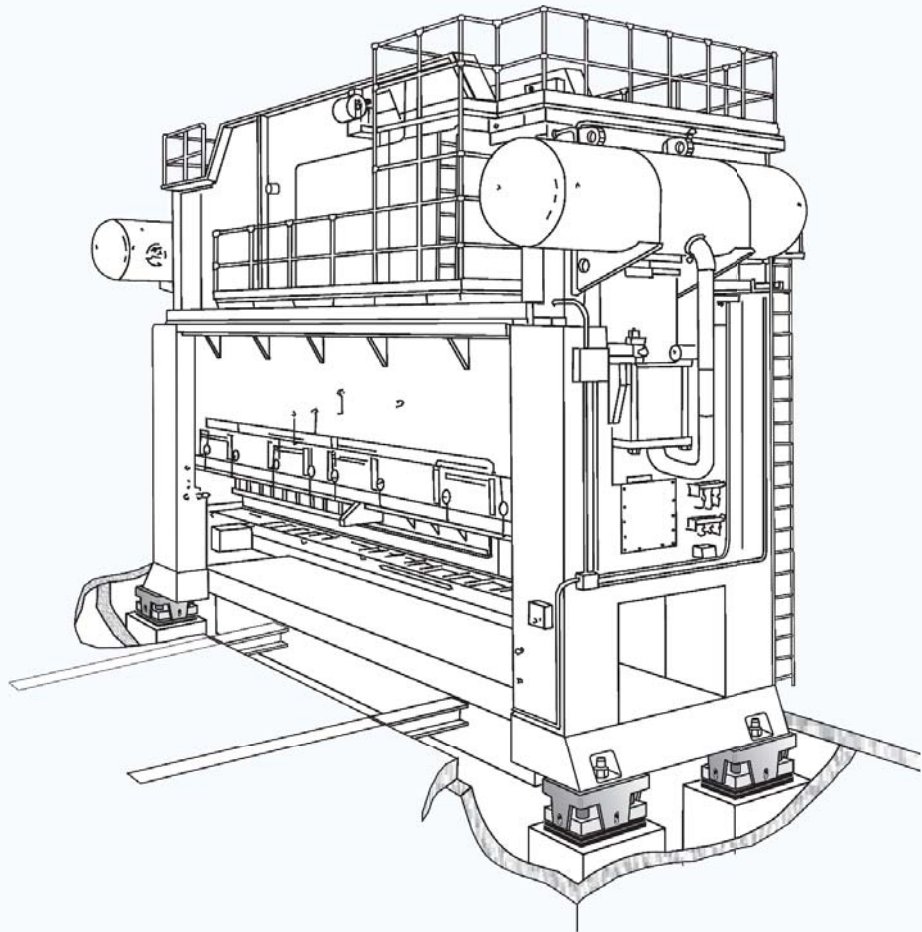

MXL™ Model



MXLP™ Model

## Features and Benefits

- Excellent isolation for effective control of vibration and shock. Typical reduction of peak vibration in surroundings of 80-90% relative to hard mounting.
- High-performance, multi-layer, modular elastomer construction.
- Stable Machine Support, Level and Alignment.
- Custom molded elastomers are engineered and applied to precisely maintain machine geometry and machine elevation for the life of the installation.
- Hydraulic Cylinder Capability
  - faster, easier leveling, alignment and elevation adjustment.
  - preventative maintenance insurance in the event of foundation settling.
- Integrated precision leveling.
  - more precise.
  - infinitely adjustable.
- Two degrees of swiveling capability.
  - uniform support.
  - eliminate foundation/grout/sole plates.

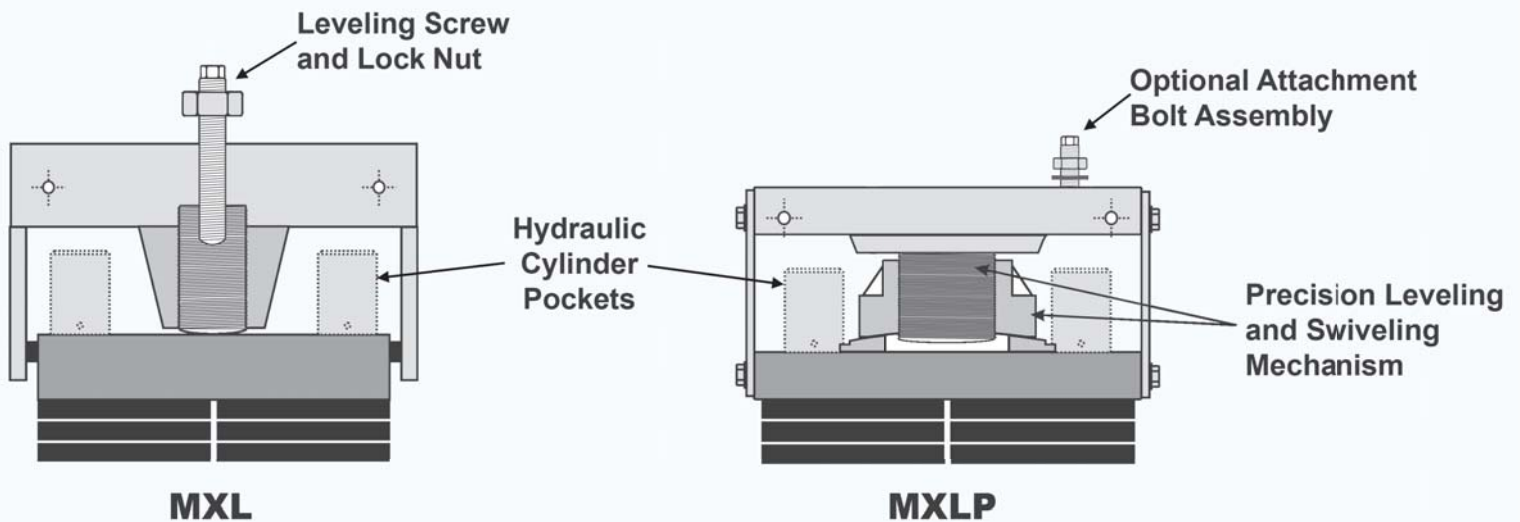

*MXL Models use a Vertical Leveling Screw arrangement to achieve precise leveling and alignment. The MXL Leveling Screw uses the machine's mounting holes, locating the MXL Isolators about the machine's mounting hole. The Leveling Screw and Lock Nut fasten the MXL to the machine foot.*

*MXLP Models have a unique Leveling Screw and Swiveling Mechanism. The MXLP Model can be located anywhere under the machine foot and does not have to be centered on the machine's mounting hole. This design offers greater layout flexibility. An optional Attachment Bolt assembly is available to fasten the Isolator to the machine foot.*

Vibro/Dynamics and Micro/Level are registered trademarks and MXL and MXLP are trademarks of Vibro/Dynamics LLC.

Vibro/Dynamics Products are protected by one or more U.S. and Foreign Patents.

### VIBRO/DYNAMICS LLC

2443 Braga Drive,  
Broadview, IL USA 60155-3941  
www.vibrodynamics.com  
email: vibro@vibrodynamics.com

Telephone: 708-345-2050  
Toll-Free: 800-842-7668  
Fax: 708-345-2225